

## Power Monitor Sensor - PMSFLXXXX

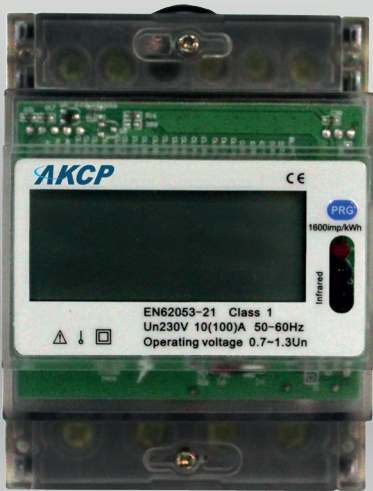

Single Phase PMS



Three Phase PMS

## Power Monitor Sensor

The ability to remotely monitor power can give a huge return on investment by providing savings in both man hours and downtime. Remote monitoring capabilities eliminate the need for manual power audits as well as providing immediate alerts to potential problems.

The Power Meter sensor is specifically designed to be used with AKCP's Linux based line of securityProbe units. Combining the Power Meter Sensor and securityProbe creates a fully IP enabled power monitoring product.

AKCP's Power Meter sensor is more rugged in design communicating through the RS485 port and is fully integrated into the securityProbe's in its own separate web interface page.

Users can be alerted when the sensor exceeds a pre-defined threshold with AKCP's industry leading notification options like: SNMP traps, email, SMS, MMS and Skype support.

Data collected over time using the Power Meter Sensor can also be viewed using the securityProbe's built in graphing tool and can be exported to external applications for analysis.

## Power Monitoring Sensor Overview

High quality, compact design and easy installation make the AKCP Power Meter Sensor an ideal monitoring solution. There are three types of the Power Meter Sensor available:

- **Single Phase**
- **Three Phase**
- **CT-Type (current transformer)**
- **Approved according to DIN standard (DIN\_43880-1988)**
- **Compact design**
- **Easy to install**
- **LCD display**
- **Record Total Active Power**

## Power Monitor Sensor Features

### Instantaneous Power Parameter Measurement

It is able to instantly measure accuracy on any power parameter

- Power
- Current RMS
- Voltage RMS

### LCD display

Most critical data can be displayed on the meters built in LCD. It can indicate both meter running status and power status.

### Local Communication

Measured data and PMS parameters are downloaded to the securityProbe via the RS485 port and with communication protocols of IEC62056-21 or Modbus.

### Maximum PMS connections to securityProbe base units

It is currently possible to monitor 14 readings from each 3 Phase PMS from the securityProbe's web interface and 4 readings from the Single Phase PMS. It is unlikely that it would be required to monitor all 14 readings, such as the power factor, however if this is required we recommend connecting roughly 6 x 3 Phase PMS's and 14 x Single Phase to a single securityProbe base unit.

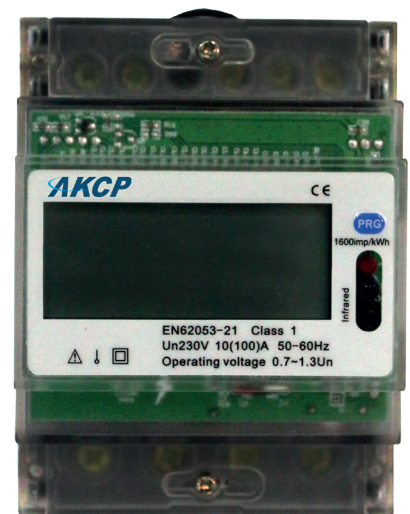

Each 3 Phase PMS can be setup to monitor up to 14 separate values as follows :

#### List of 3 Phase values

- 3 Voltages (each phase line  $\pm 0.5\%$ )
- 3 Amps (each phase line  $\pm 0.5\%$ )
- 3 Power Factor (each phase line  $\pm 0.2\%$ )
- 3 Active Power (each phase line  $\pm 0.5\%$ )
- 1 Frequency  $\pm 0.2\%$
- 1 Active Energy  $\pm 1\%$

Each Single Phase PMS can be setup to monitor up to 4 separate values as follows :

#### List of Single Phase values

- Voltage  $\pm 0.5\%$
- Amps  $\pm 0.5\%$
- Frequency  $\pm 0.2\%$
- Active energy  $\pm 1\%$

	Single Phase Meter	Three Phase Meter	Three Phase Meter - CT Type
<b>Voltage (V)</b>			
Rated Voltage (Un)	230V AC	230/400V AC (3~)	230/400V AC (3~)
Operational Voltage Range	0.7~1.3Un	161/279 – 300/520V AC (3~)	161/279 – 300/520V AC (3~)
<b>Current (A)</b>			
Basic Current (Ib)	10A	10A	1.5A
Maximum Current	100A	100A	6A
Operational Current Range	0.4% Ib- I <sub>max</sub>	0.4% Ib- I <sub>max</sub>	0.4% Ib- I <sub>max</sub>
Over Current Withstand	30I <sub>max</sub> for 0.01s	30I <sub>max</sub> for 0.01s	30I <sub>max</sub> for 0.01s
Internal Power Consumption	≤2W / 10VA	≤2W / 10VA per phase	≤2W / 10VA per phase
<b>Frequency (Hz)</b>			
Operational Frequency Range	50~60Hz ±10%	50Hz ±10%	50Hz ±10%
<b>Operating Environment</b>			
Operating humidity	≤ 75%	≤ 75%	≤ 75%
Operating temperature	-10°C - +50°C	-10°C - +50°C	-10°C - +50°C
International standard	IEC 62053-21	IEC 62053-21	IEC 62053-21
<b>Accuracy Class</b>			
Voltage	±0.5%	±0.5%	±0.5%
Amps	±0.5%	±0.5%	±0.5%
Frequency (Hz)	±0.2%	±0.2%	±0.2%
<b>Dimensions</b>			
Height	100 mm	130 mm	130 mm
Width	76 mm	126 mm	126 mm
Depth	65.5 mm	65 mm	65 mm
Max Diameter Cable	11.5 mm		
Weight	0.35 Kg	0.7 Kg (net)	0.7 Kg (net)

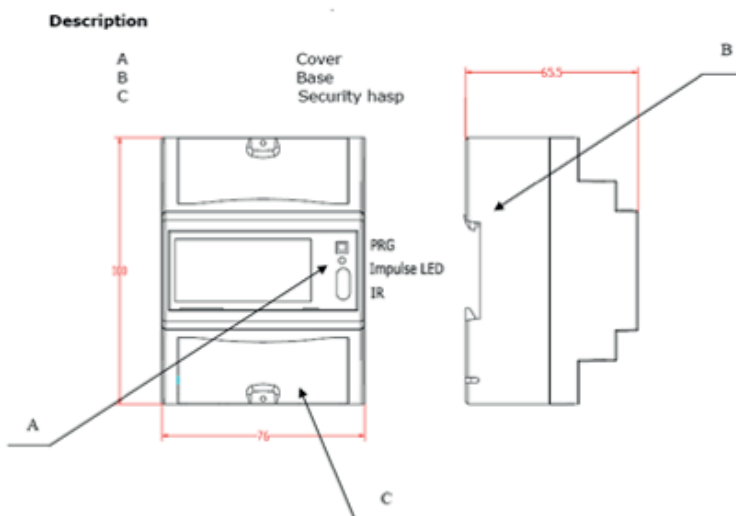

Single Phase PMS

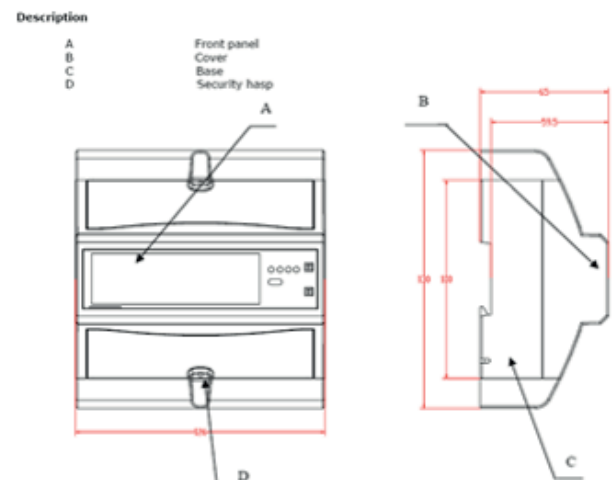

3 Phase & 3 Phase CT Type PMS